

# Installation Guide (For BKT-M595)

BKT-M595

**Important Notes:**

All Plasma / LCD TV brackets are thoroughly inspected and fully tested operational in factory. We accept no liability whatsoever for any losses due to improper operation, or any unauthorized alteration. All trademarks contained in this installation guide are the property of their respective owners

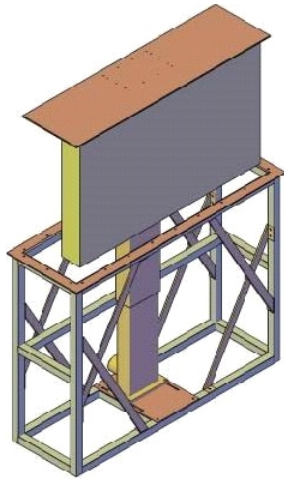

**Radio Frequency Remote Control**

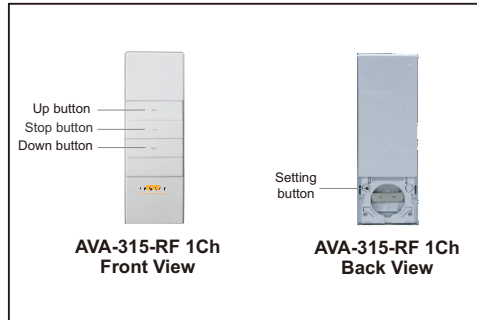

**Remark:**  
Dry Contacts for A/V Control System (e.g. AMX / Creston) Available

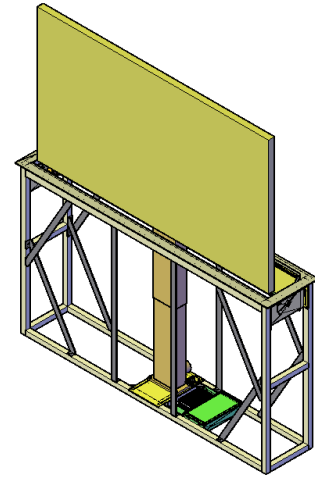

**BKT-M595 Motorized TV Lifter  
(Top Cover-Type1)**

**BKT-M595 Motorized TV Lifter  
(Flip Cover-Type2)**

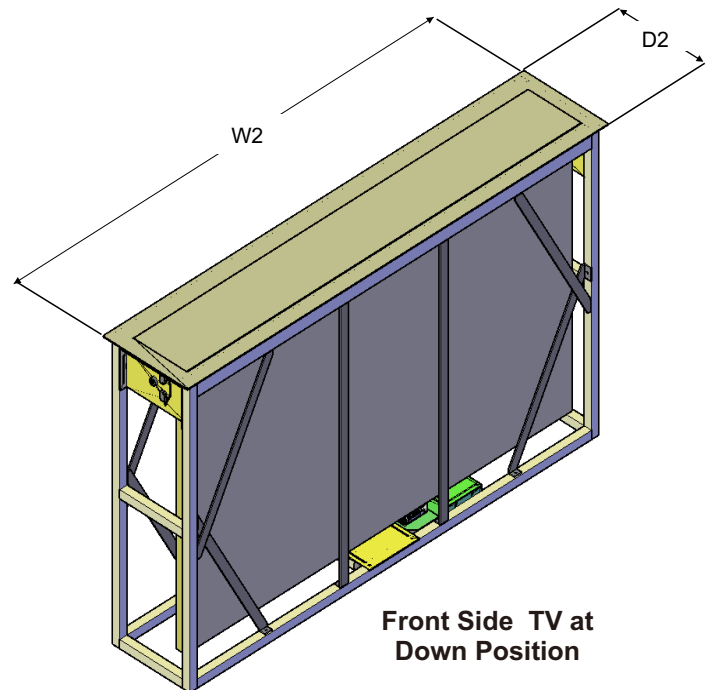
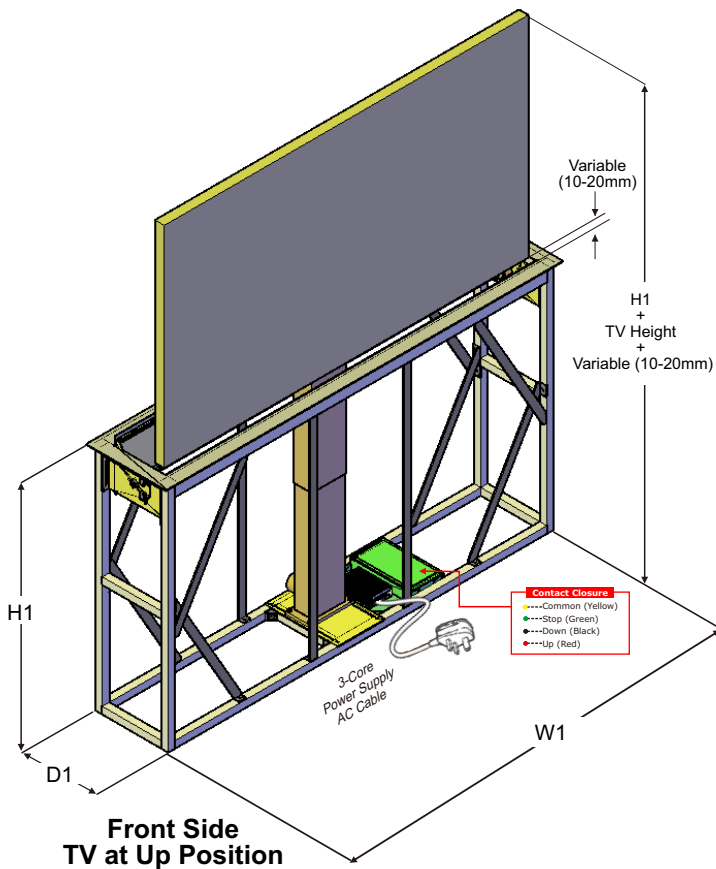

**Front Side  
TV at Up Position**

**Front Side TV at  
Down Position**

|                    | W1   | D1  | H1   | W2   | D2  | Max.TV Size              |            |
|--------------------|------|-----|------|------|-----|--------------------------|------------|
|                    |      |     |      |      |     | (Width x Depth x Height) | (Diagonal) |
| <b>BKT-M595C/S</b> | 1037 | 325 | 851  | 1087 | 360 | W980 x D41 x H616        | 42"        |
| <b>BKT-M595C/M</b> | 1556 | 325 | 851  | 1606 | 360 | W1470 x D41 x H755       | 55"        |
| <b>BKT-M595C/L</b> | 1770 | 325 | 1063 | 1820 | 360 | W1672 x D41 x H963       | 75"        |



All controls support 230V/50Hz

### AVA-350A Radio Frequency Receiver



| Description          | AVA-350A-RF Receiver |
|----------------------|----------------------|
| Input Voltage        | 230 VAC              |
| Frequency            | 433 MHz              |
| Power                | 100 Watts            |
| Work Temperature     | -10°C - 50°C         |
| Sensitivity Distance | 20m                  |

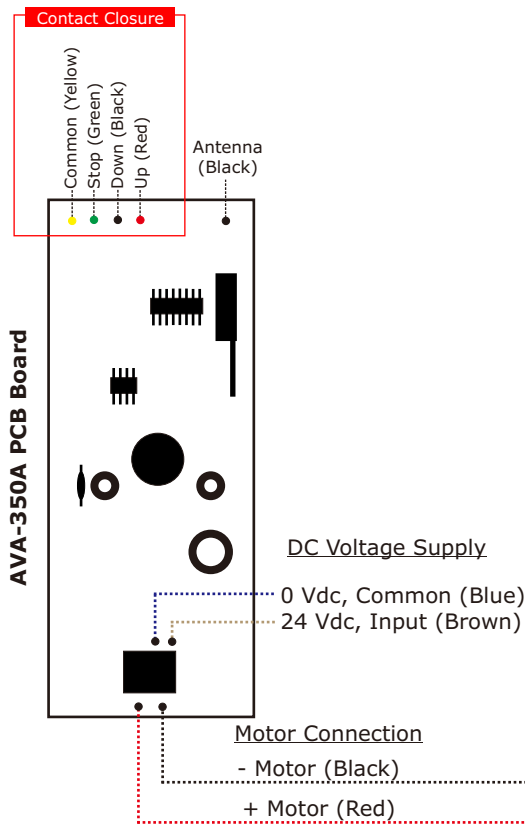

### A/V Equipments

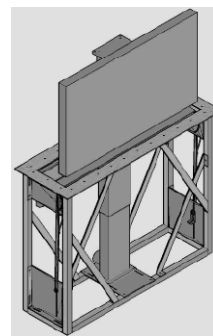

BKT-M595 LCD Motorized Lifter

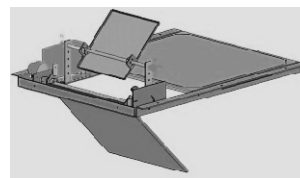

ATM-470C Automatic Mirror System

### OPTION

### AVA-350A compatible with AVA-315 1-Channel Radio Frequency Remote

#### Pairing AVA-350A with AVA-315-RF 1Ch

